

LK Pro² Kirschner Tipper + Robot Pro

The Robot Pro adds fully automatic loading and unloading of circular saw blades on the LK Pro2 Kirschner Tipper.

Features

- Horizontal storage of the saw bodies and circular saws
- Loading/unloading mandrels available in Kirschner or Vollmer style options
- Double gripper system with electro magnets
- Saw body level-off function
- Extremely compact design with common base frame
- Best accessibility due to complete opening and possible crane loading
- Spacers/intermediate layers optional

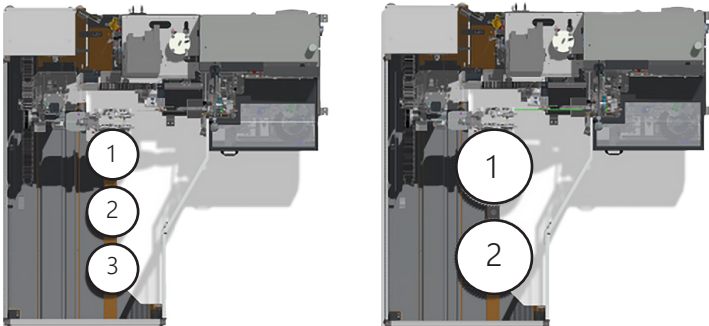

LK Pro ² Kirschner Tipper + Robot Pro Specifications	
Robot Pro Loader	Ø 3.9" to 33.5"
LK Pro ² w/ Robot Pro	-10" to +32"
Machine dimension	Approx. 85" W x 110" D x 84" H
Weight	Approx. 3,197 lbs

Kirschner System

- Mandrel length: 360mm (14.2")
- Usable length: 350 mm (13.78" saw capacity)

Vollmer System System

- Mandrel length: 320mm (12.6")
- Usable length: 310 mm (12.20" saw capacity)

*Loading and unloading mandrels from Kirschner or Vollmer can be used. The version selection must be made when ordering the loader.

Toll-Free +1 800 426 6226 | Direct +1 541 683 3337

135 LK Pro² Kirschner Tipper + Robot Pro 202309 © Burton Mill Solutions



info@burtonmill.com | burtonmill.com



For more than a century, Burton Mill Solutions has been cultivating its network of products and services to meet your needs and help you to operate at the top of the industry. With our strategic family of product brands, we're certain that we can provide you with the best quality tools and products to get the job done right.

12 Factories and Regional Distribution Centers to serve you better.

Ridgefield, WA • Springfield, OR • Little Rock, AR • West Monroe, LA
Northport, AL • Hampden, ME • Fitchburg, MA • Florence, SC
Fountain Inn, SC • Big Raids, MI • Salmon Arm, BC • Lévis, QC